

FRONT VIEW

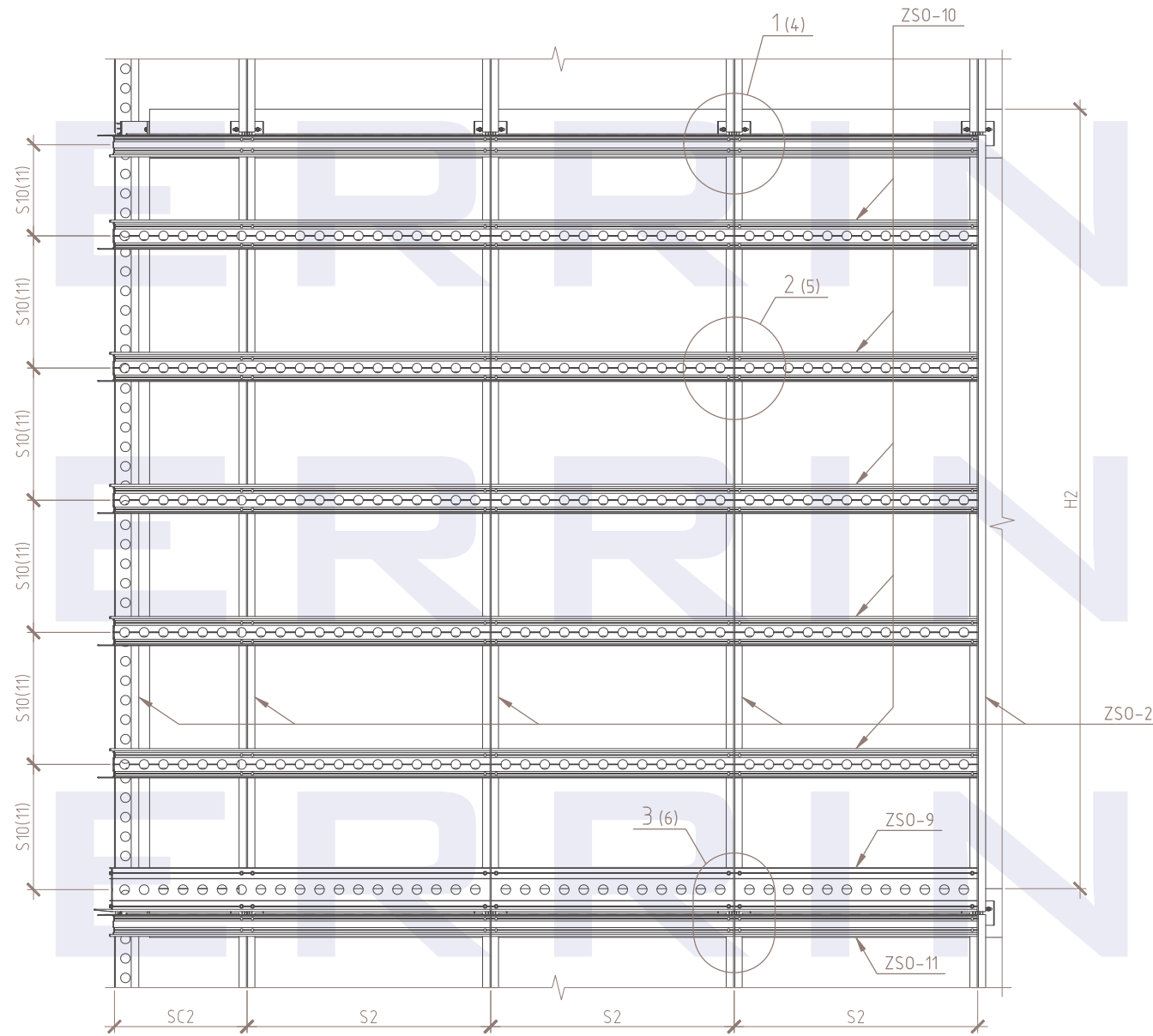

ELEVATION VIEW

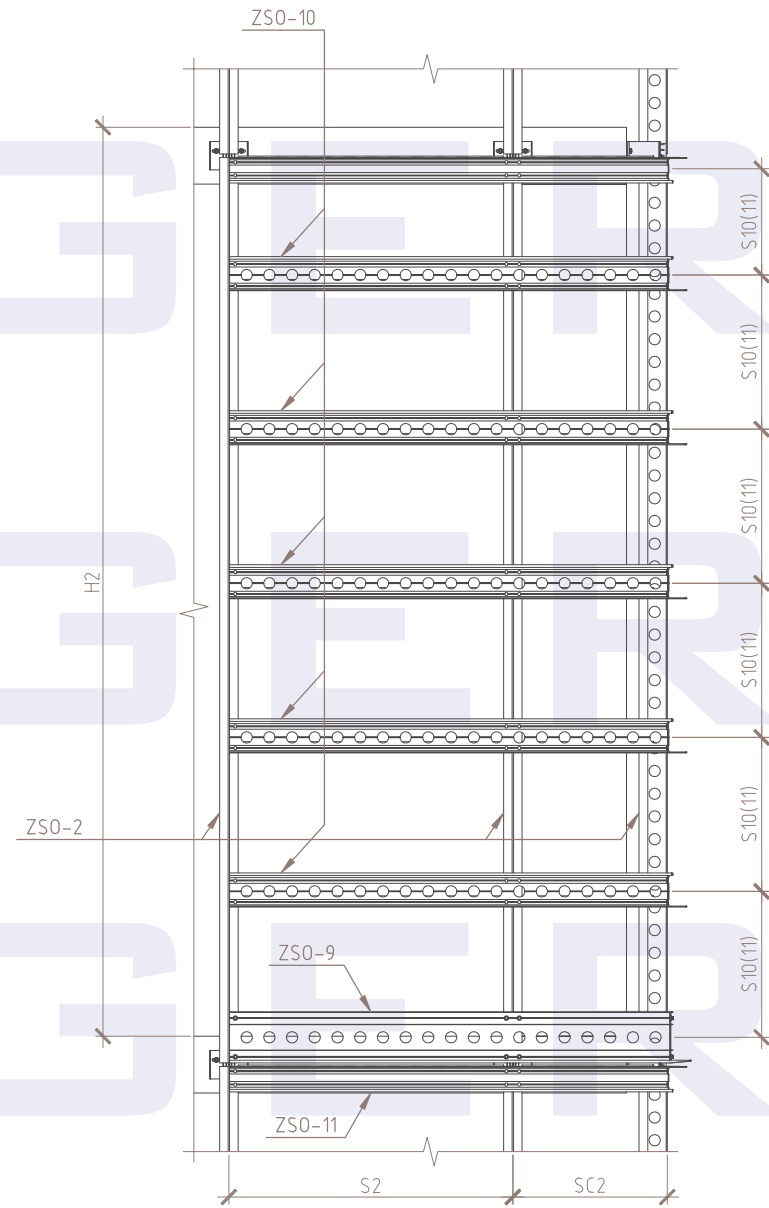

TOP VIEW

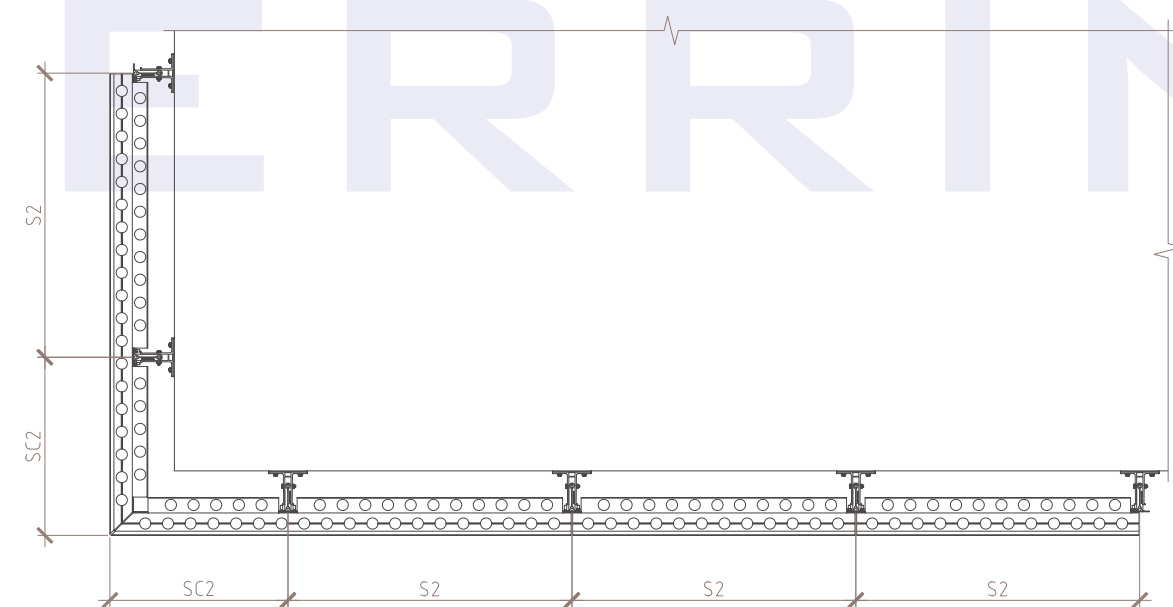

ISOMETRIC VIEW

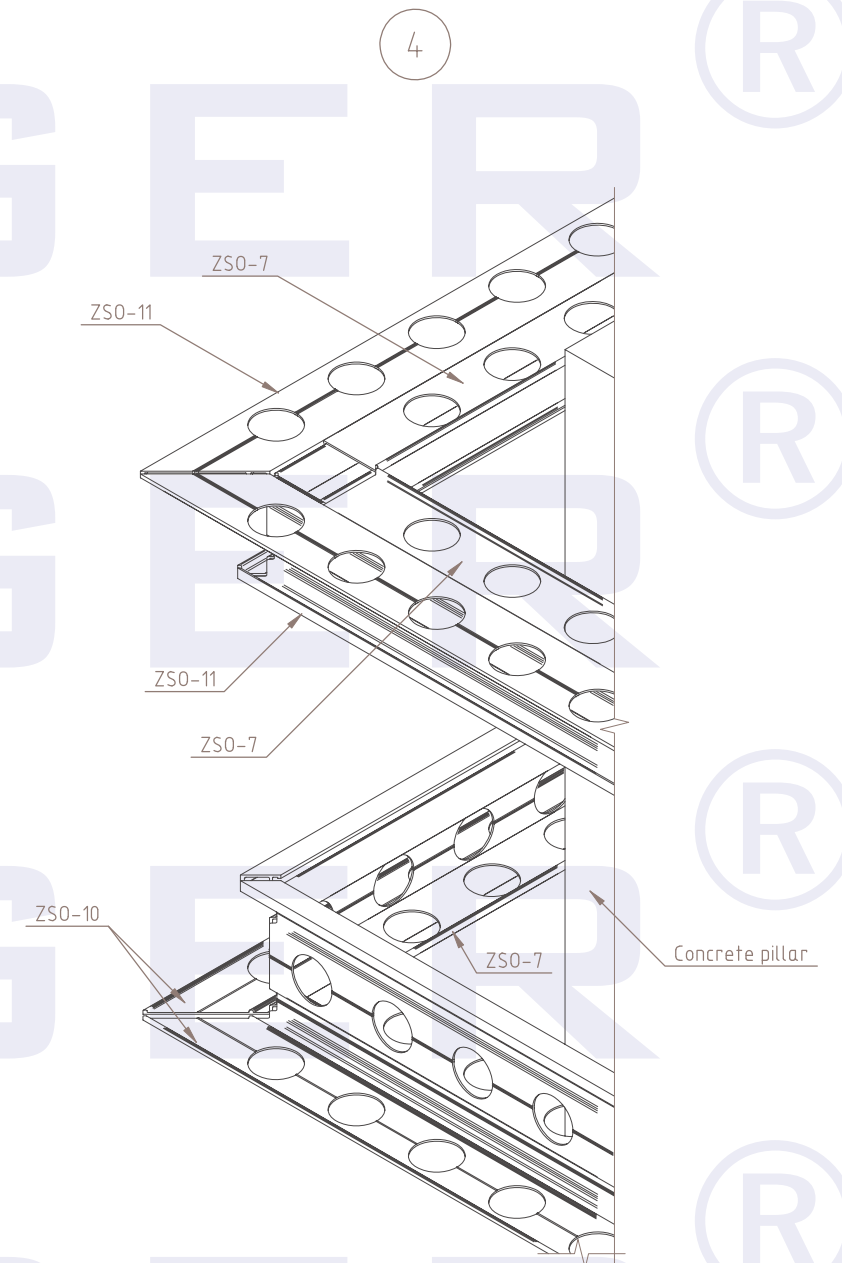
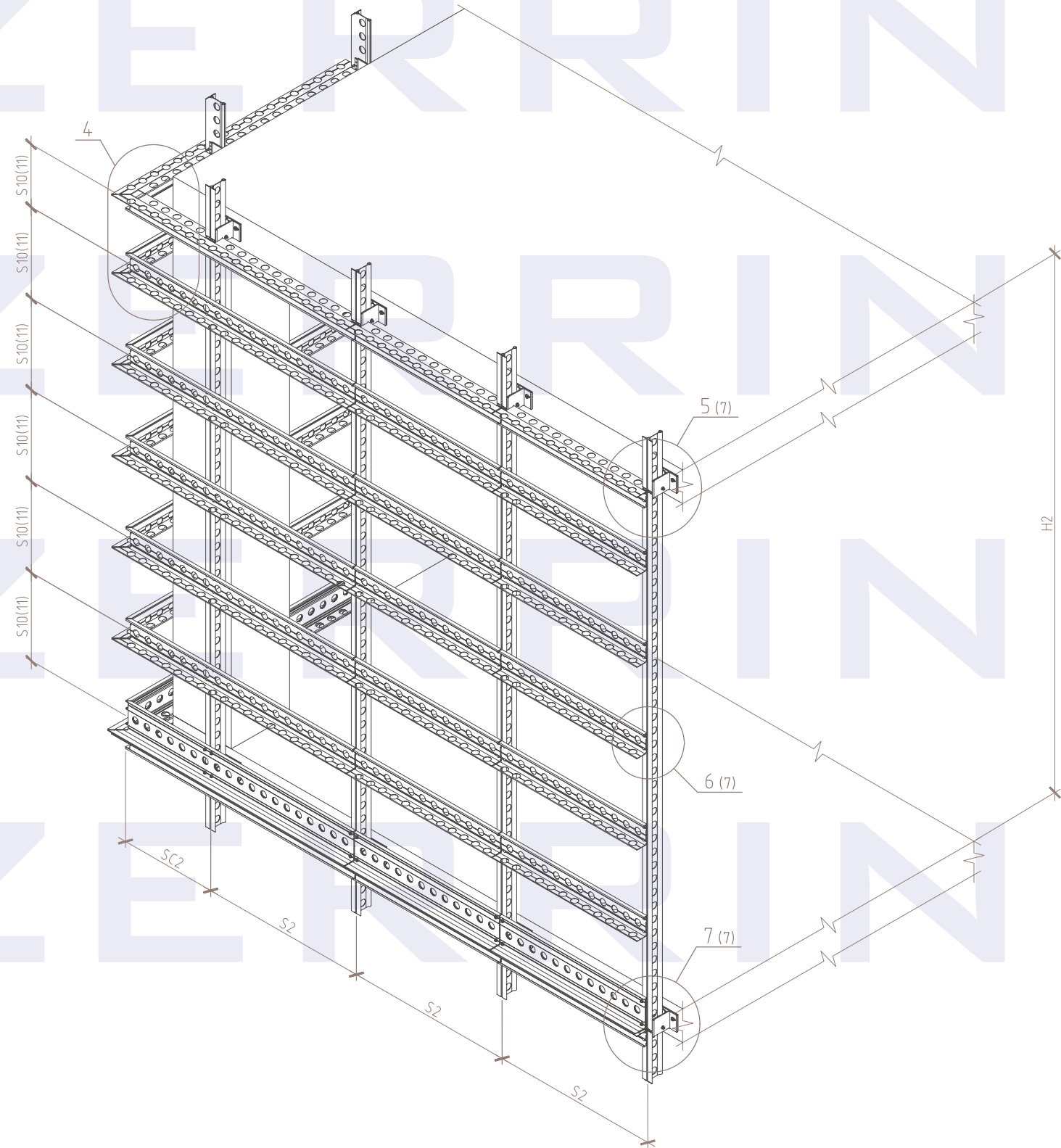

Stone subframe

ISOMETRIC VIEW

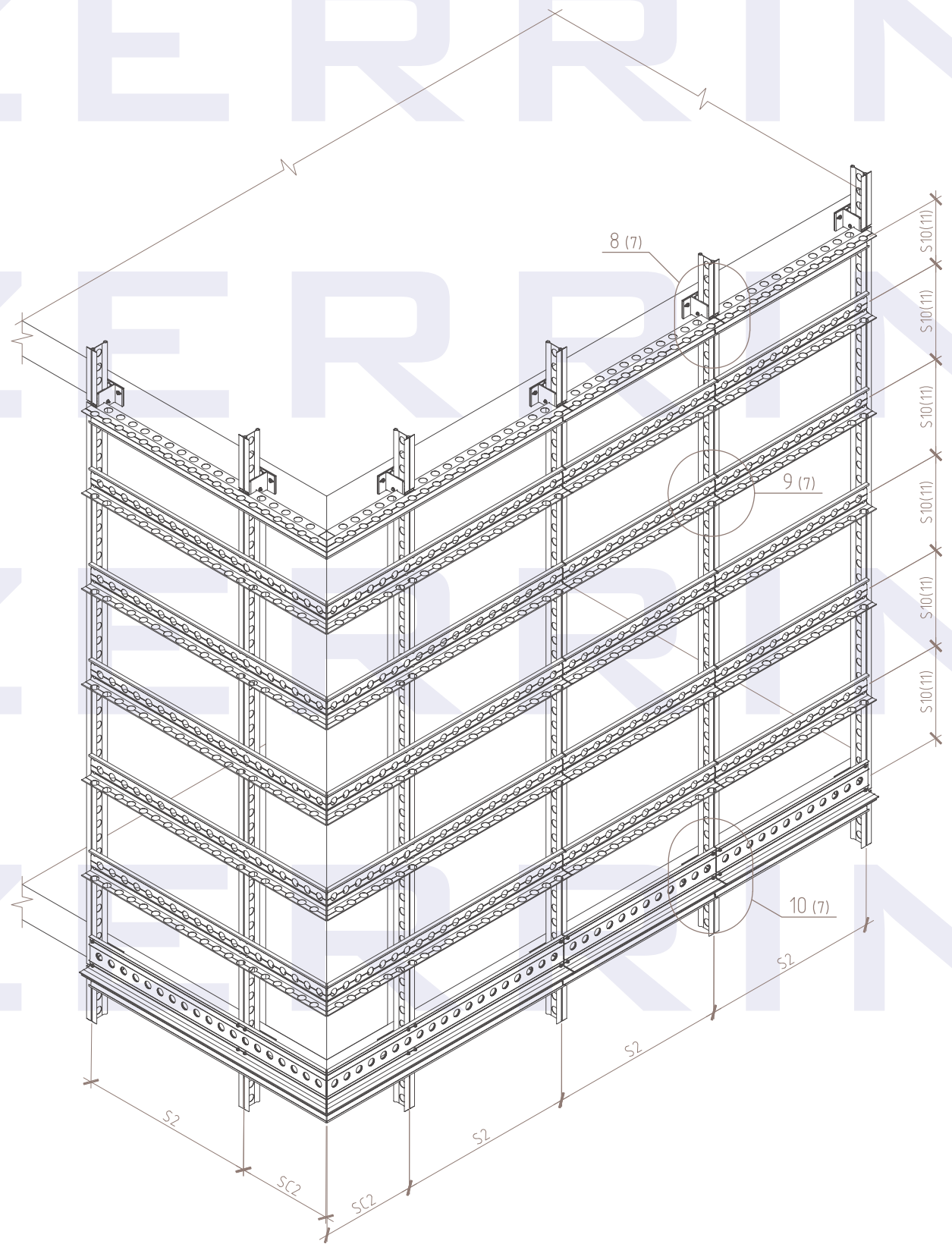

ZERRINGER

ZERRINGER.SnapOn.Stone.Subframe

Limestone. Frame details

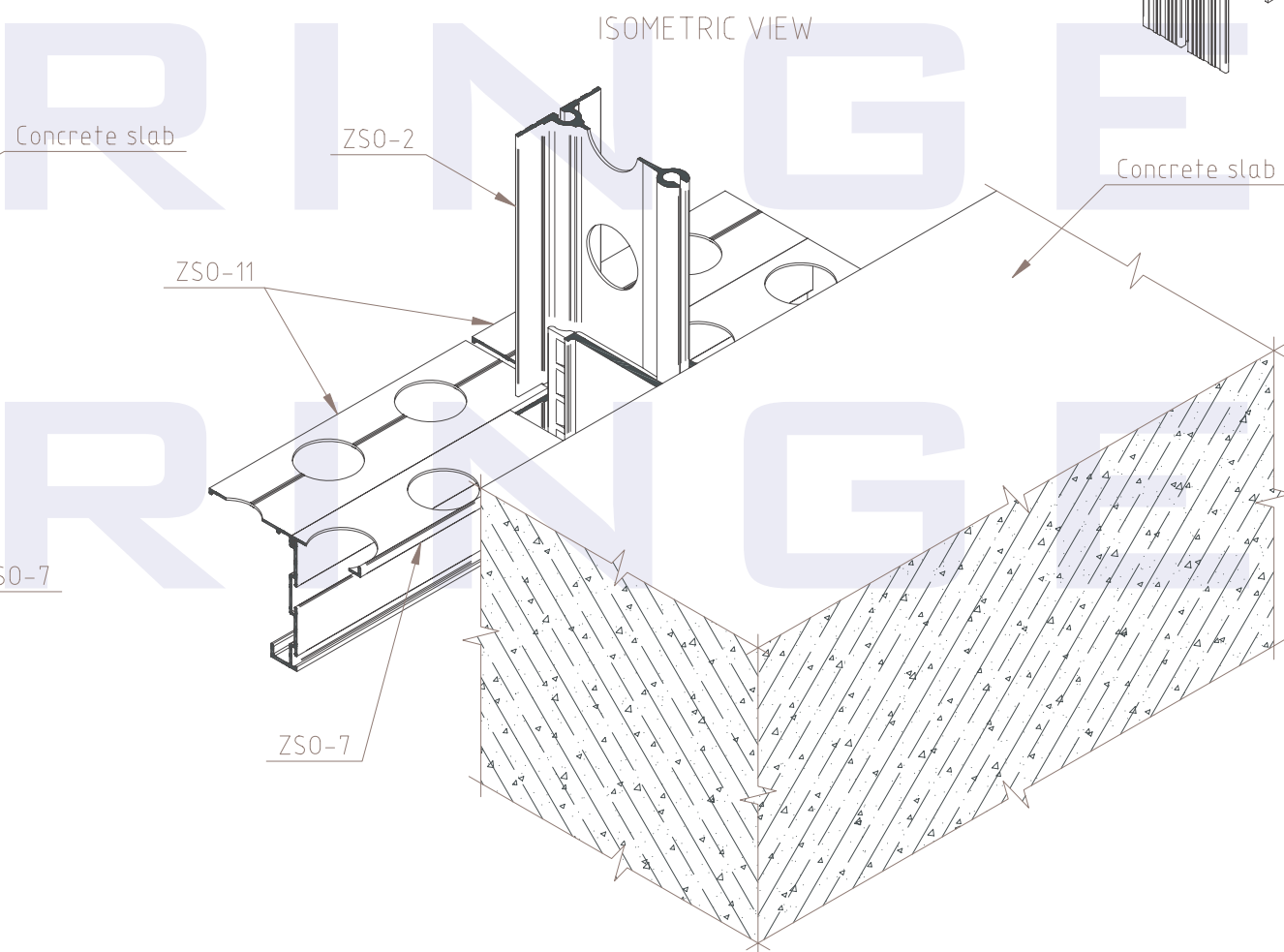
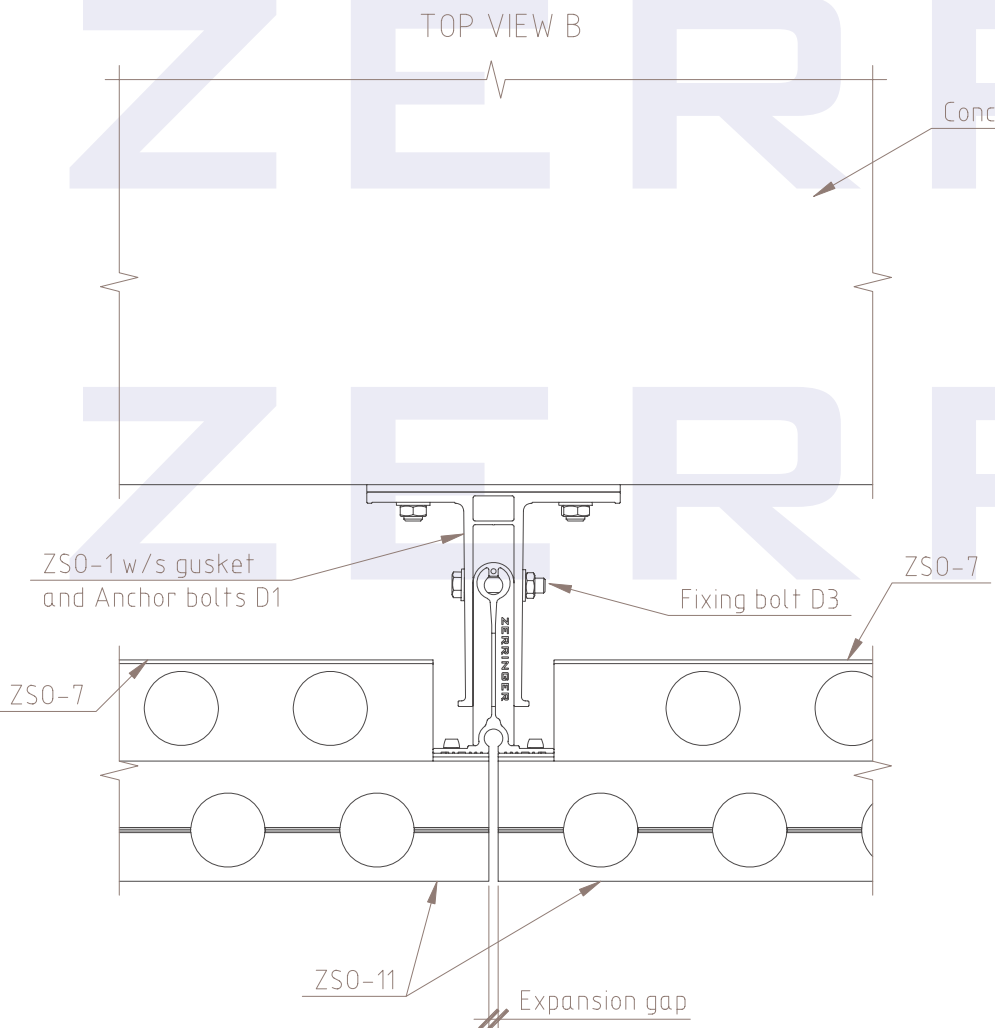
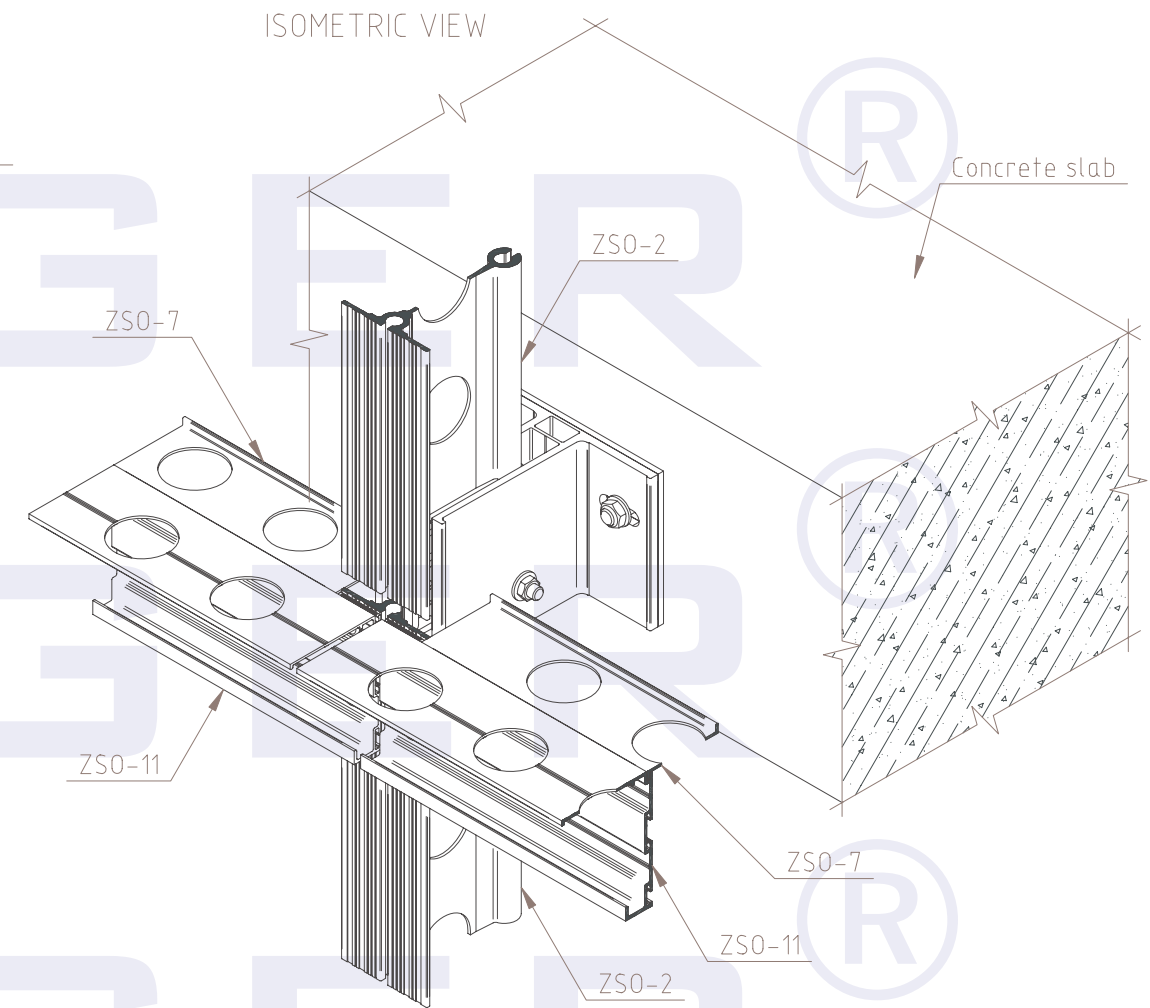
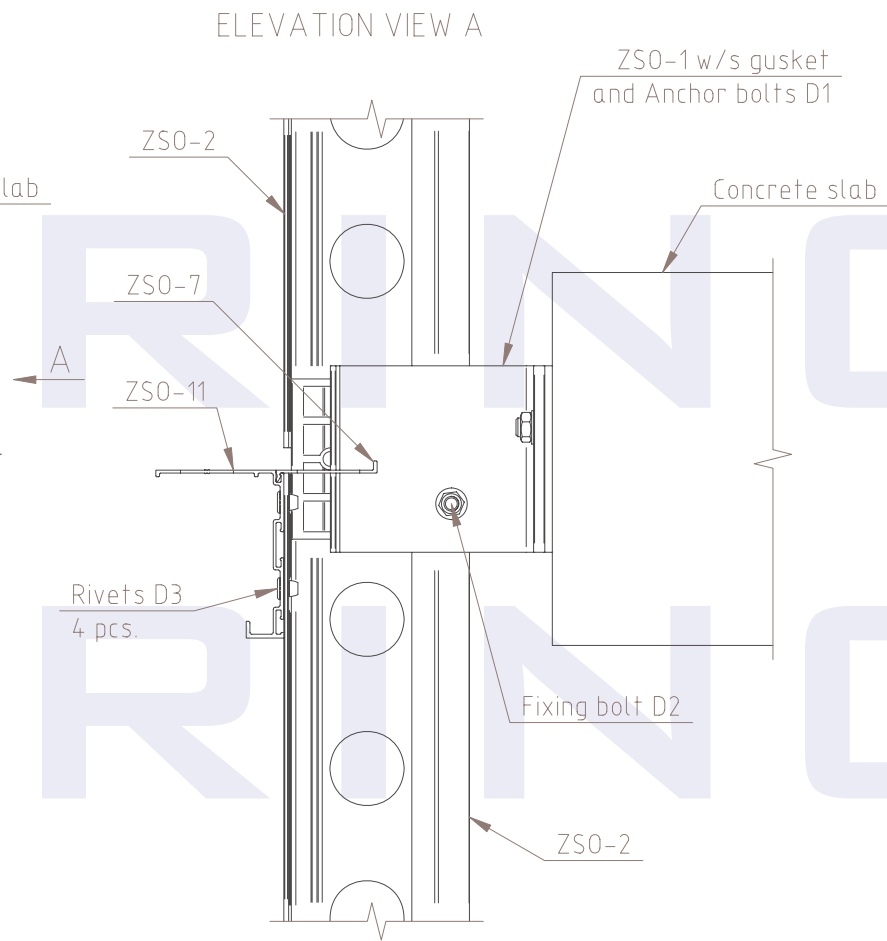
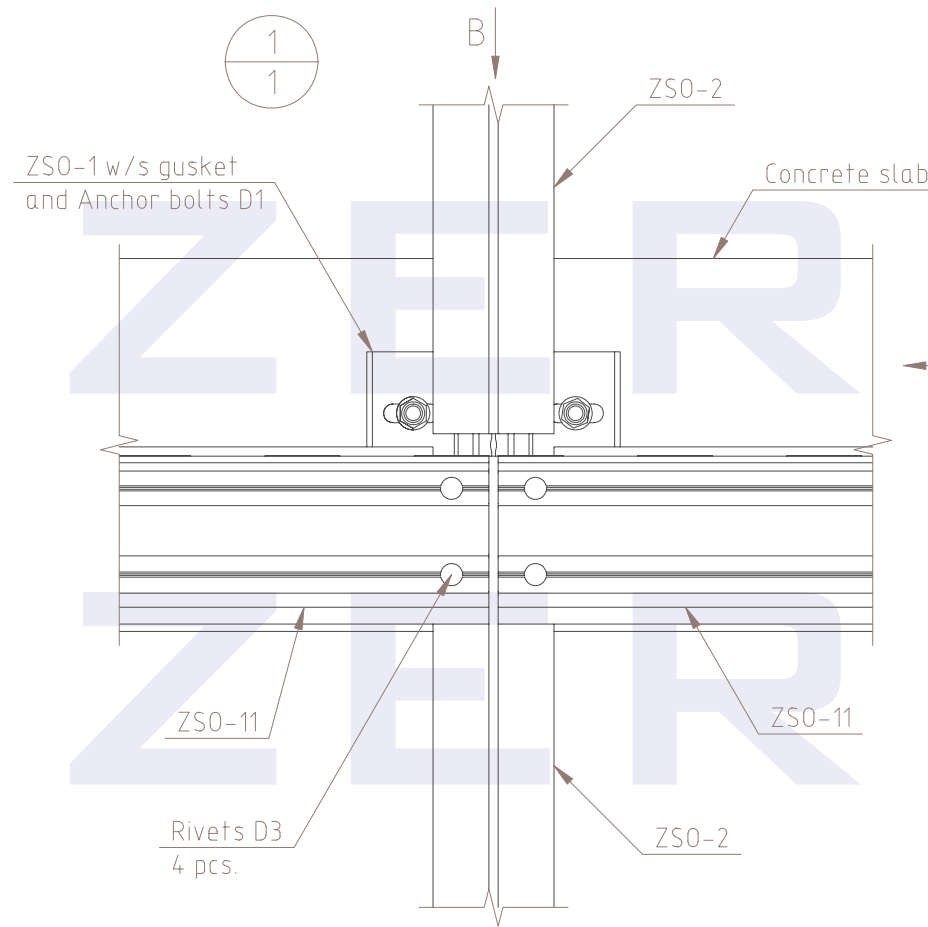

ZERRINGER

Limestone. Frame details

2
1

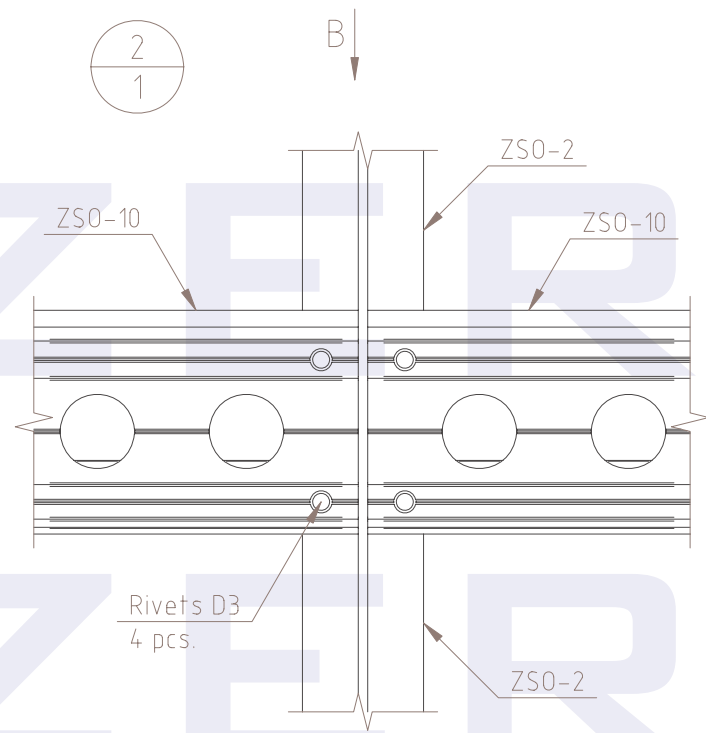

ELEVATION VIEW A

ISOMETRIC FRONT VIEW

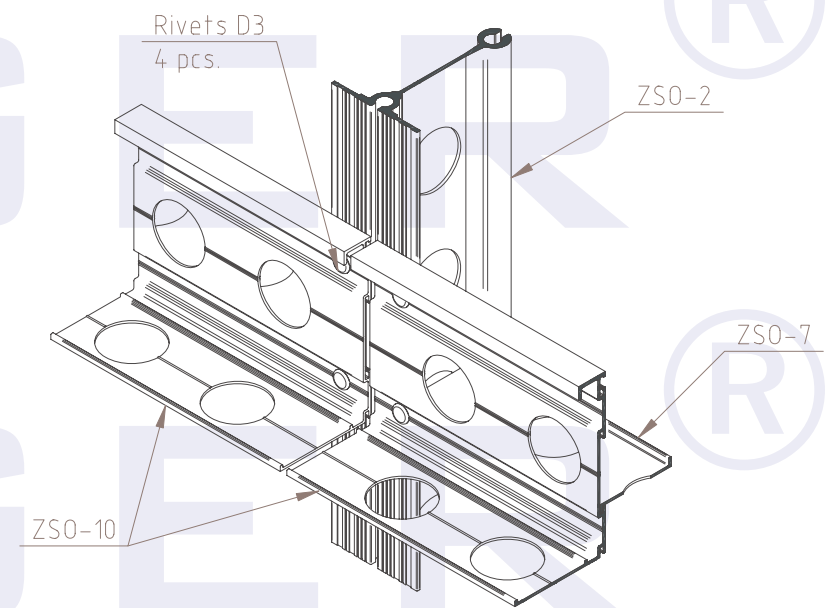
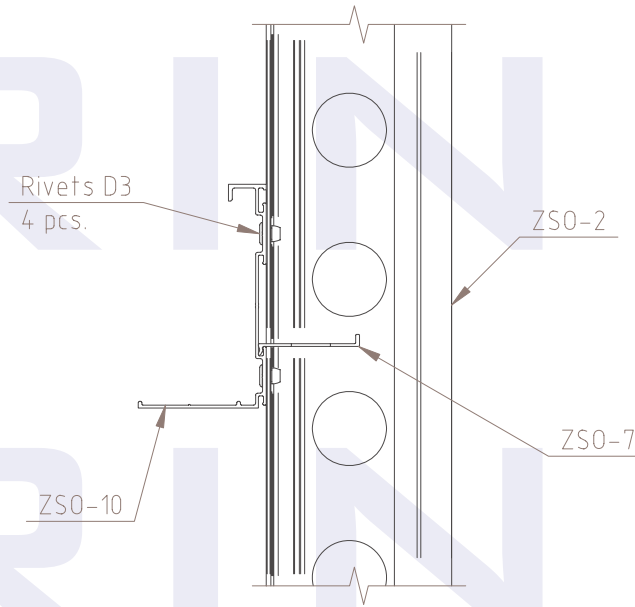

TOP VIEW B

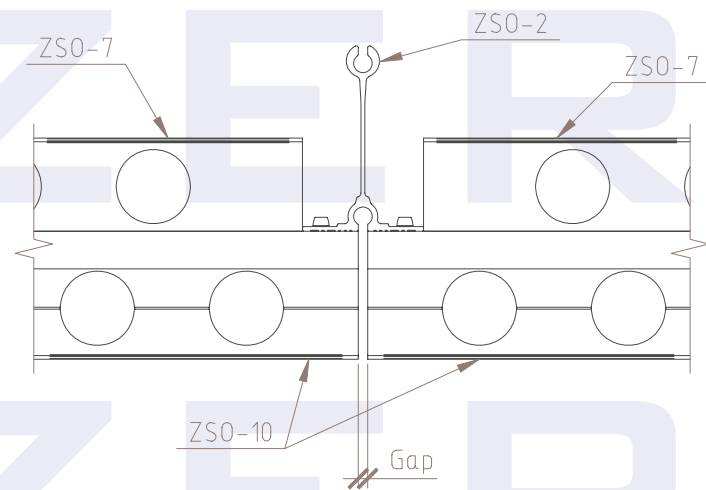

ISOMETRIC BACK VIEW

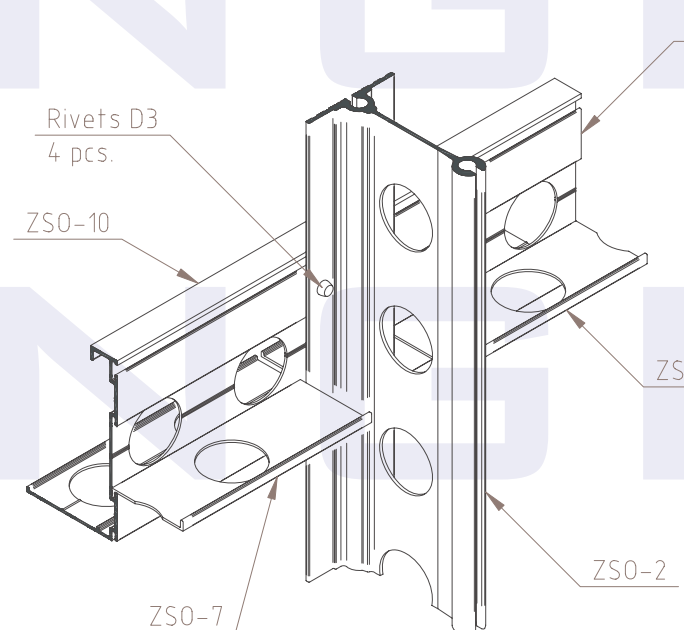

Fixing detail (D3)

Fixing method:

- blind rivets
- thread cutting screws

Rivets (according to stress calculations) -

- 4.8 - Al(Mg 3.5)-ST DIN 7337;
- 6.0 - Al(Mg 3.5)-stainless steel AISI 304 DIN 7337.

Self-tapped bolts - TEX 4.8x13, 4.2x16 DIN 7504 N

Anchors - HILTI HIT-RE 500 - HAS (HAS-5.8, ISO 898 T1, galvanize min 5 mkm, HAS-R stainless steel A4-70; 1.4401, 1.4404, 1.4571).

See also developer's recommendation.

ZERRINGER

Limestone. Frame details

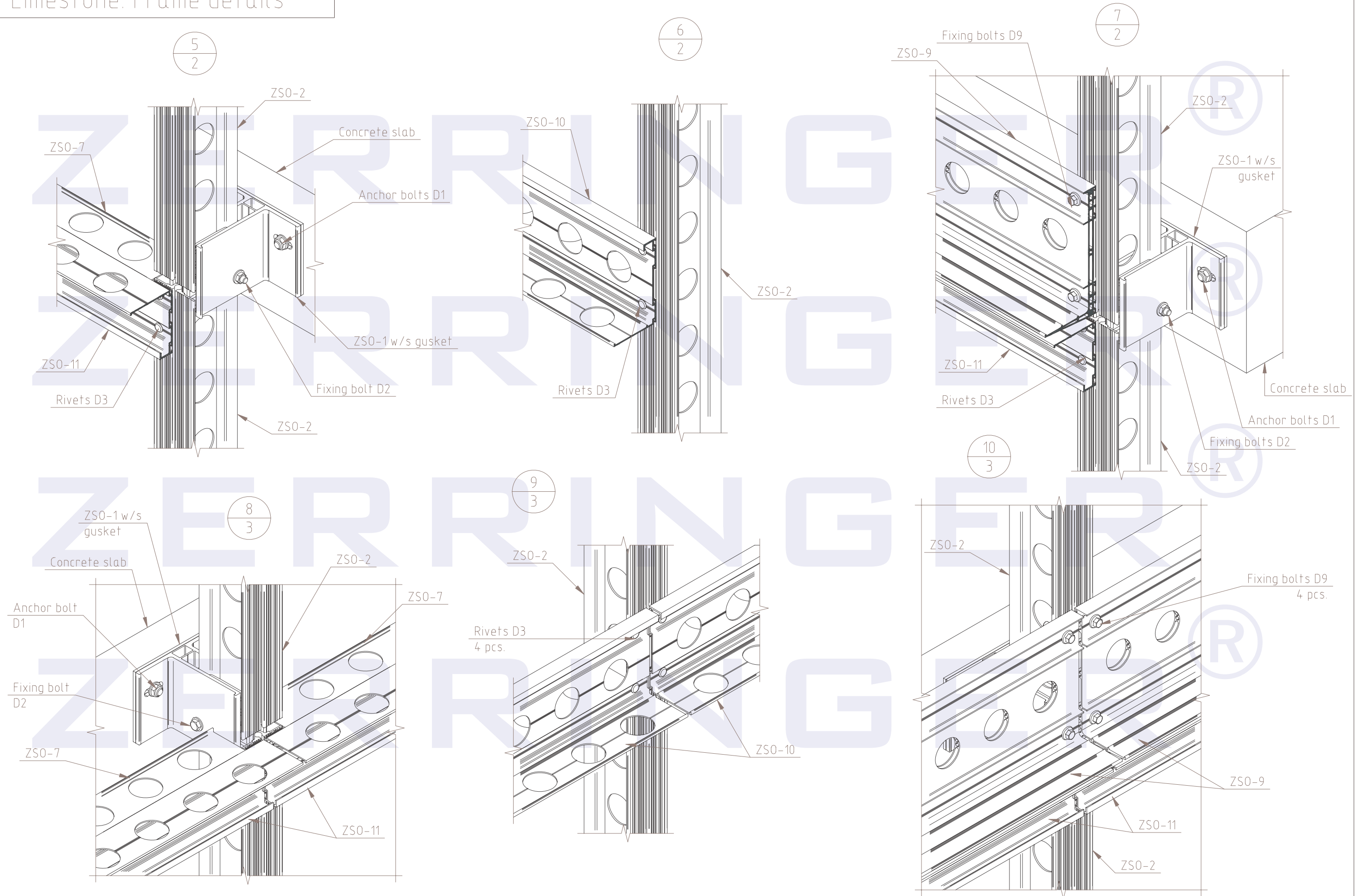

ZERRINGER

ELEVATION VIEW (blank wall)

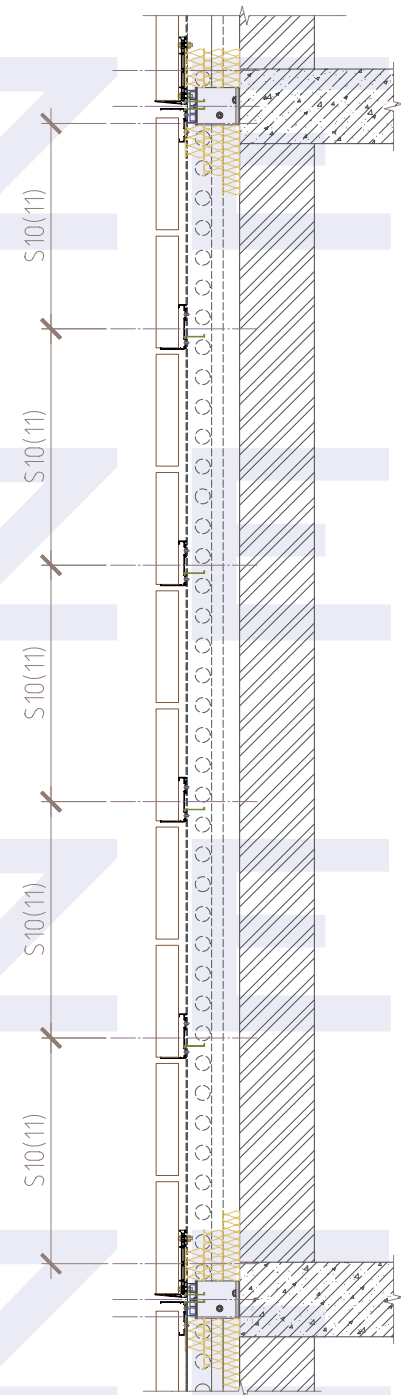

ELEVATION VIEW (wall with window opening)

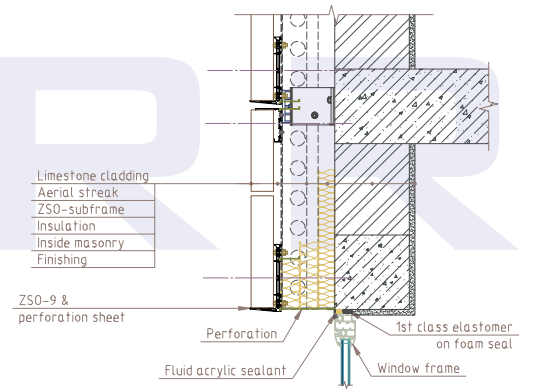

ELEVATION VIEW (parapet)

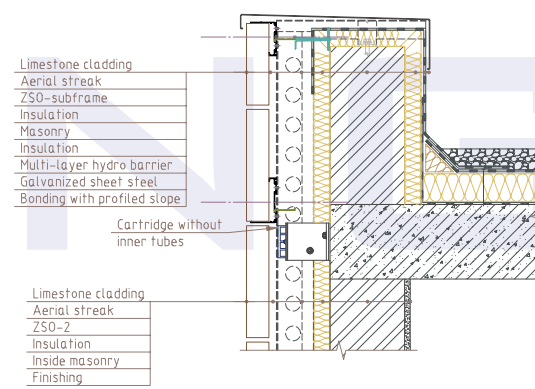

ELEVATION VIEW (balcony)

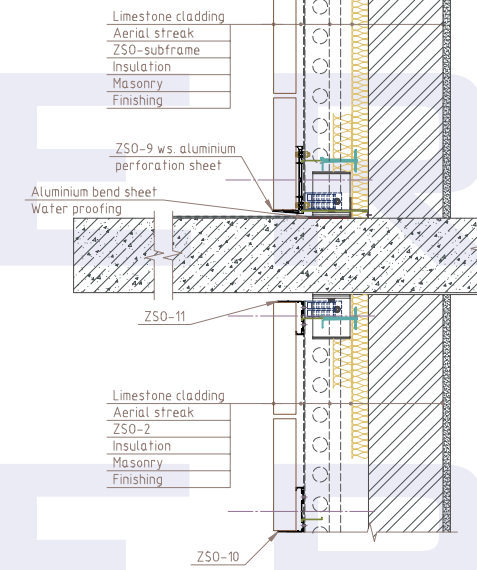

ELEVATION VIEW (wall with window opening)

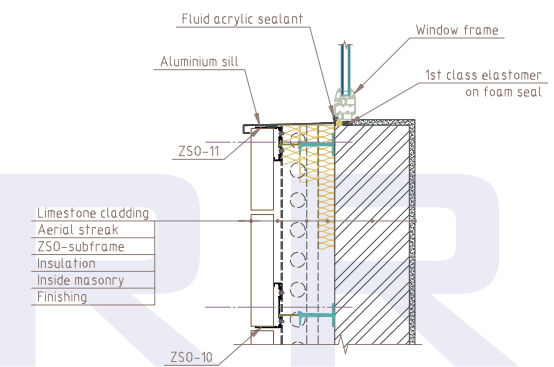

ELEVATION VIEW (overlapping detail)

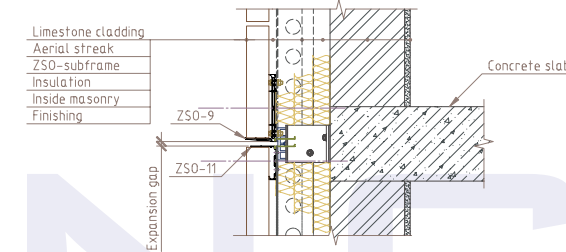

ELEVATION VIEW (balcony) - variant

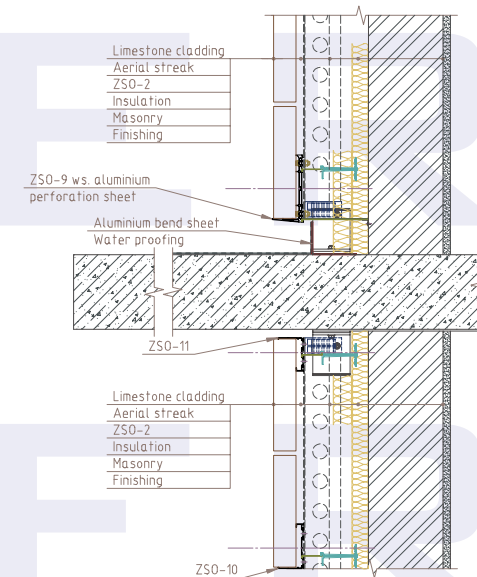

ELEVATION VIEW (basement)

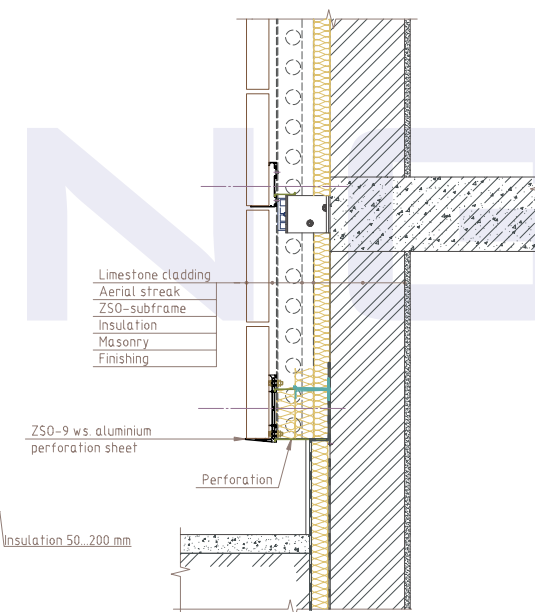

TOP VIEW (window opening)

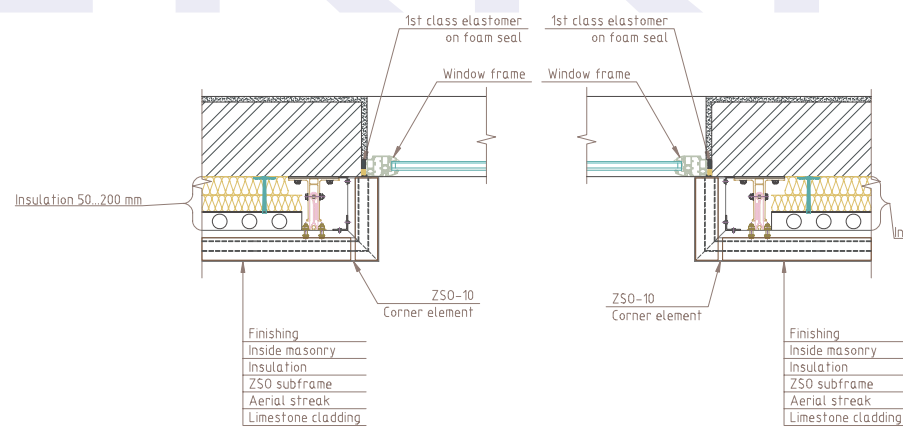

TOP VIEW - external corner

TOP VIEW - internal corner

